

GASCHECK G4 GAS LEAK DETECTOR

edwardsvacuum.com

The GasCheck G4 features an improved Micro Thermal Conductivity sensor for enhanced sensitivity and piezo disc pump for increased reliability.

At the heart of the instrument is a sensor which can detect any gas with a different thermal conductivity to that of air. Leaks can be located and the gas leak rate can be displayed in a choice of convenient units.

Datalogging is now possible over a long period of time (up to 10 days continuous) meaning less back and forth to download data. With the G4, you get a lightweight carry case which holds all the key accessories (delivered as standard) and it also protects the unit during transit.



direct display of gas leak rate



Large LCD colour display



10 days of data logging



Features and benefits

- Detect leaks with automatic and direct display of gas leak rate
- Large LCD colour display with intuitive control and value displays
- Choice of readings in cc/sec, mg/m³h⁻¹ or ppm, g/yr and %vol
- Rapidly detects almost any known gas – particularly sensitive to ammonia, argon, butane, helium, xenon
- Data-logging facility – 10 days of continuous logging
- Ergonomically designed for portable one handed operation - IP44 protection, ruggedised design, rechargeable Li-ion battery (up to 20 hours) and lightweight

Typical applications

- Leak detection of new installations & serviced equipment
- Leak detection of welds, joints, seams and gaskets on components that are pressurised with a traceable gas such as helium or carbon dioxide
- Leak testing refrigeration plants
- Leak check on cylinders and aerosols
- Used in mass spectrometry and gas chromatography
- Leak detection in environments with a high magnetic stray field



Technical data

Detector	Micro thermal conductivity detector (MTCD)
Battery type	Rechargeable Li-ion battery
Battery life	20 hours
Audible alarm	≥90 dBa at 10 cm at 50 % relative humidity (room temperature)
Factory calibration	5000 ppm helium (±5%) Leak: 0.0005 cc/sec (±5%)
Data logging	10 days continuous
Response (T90)	1 second
Flow rate	2 cc/s
Ingress protection	IP44
Temperature	Operating: 0°C to 50°C
Humidity	0 - 99% R.H
Weight	447g (approx.)
Dimensions - instrument	320 x 80 x 55 mm (approx.)
Dimensions - case	950 x 340 x 100 mm

Ordering information

Product description	Order no.
GasCheck G4 leak detector	D14135000
Accessories and spares	
Communications interface dongle	D14135500
Flexible probe 200mm for GasCheck G4	D14135501
Probe sleeve (pack of 5)	D14135502
Capillary probe - standard (10 mbar restriction)	D14135503
Nozzle	D14135504
Capillary probe - short (for 200mm flexible probe)	D14135505

Dimensions

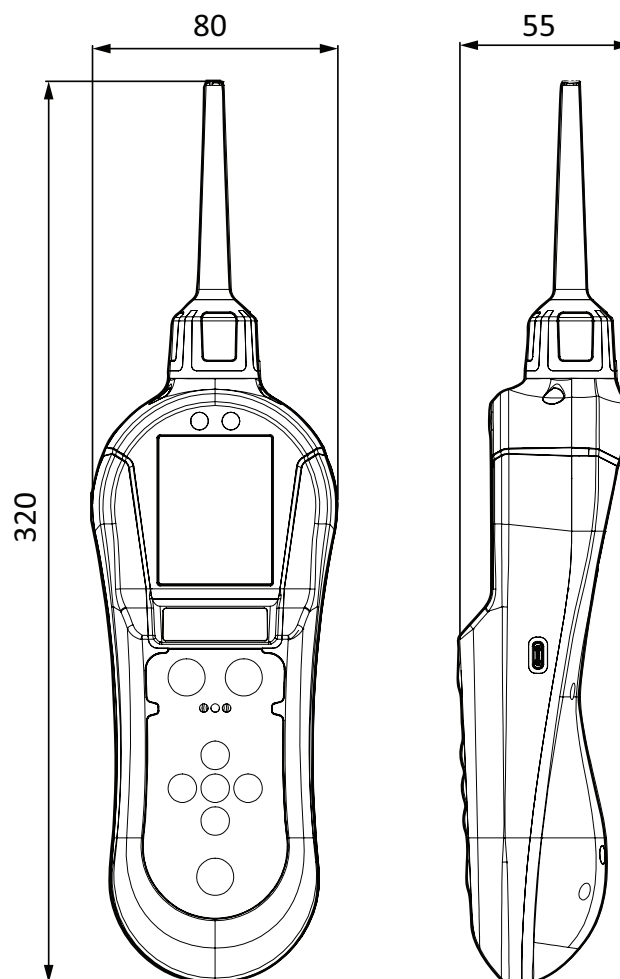

Smallest detectable leak levels

Name	Abbreviation	Response factor (He=1)	Minimum sensitivity cc/sec
Hydrogen	H2	0.648	5.00E-6
Helium	He	1.000	3.20E-6
Sulphur hexafluoride	SF6	1.448	7.20E-6
Carbon dioxide	CO2	5.576	2.80E-5
Methane	CH4	4.007	2.00E-5
Argon	Ar	6.599	3.30E-5
Oxygen	O2	22.582	1.10E-4
Refrigerant	R134a	2.88	1.40E-5
Refrigerant	R14	2.246	1.10E-5
Gas Group 2B	2.5		

For other gas types please contact Edwards for more information

GasCheck G GAS TABLE

Gas name	Trade name	Formula	Molecular weight	Gas group
Air				
GAS GROUP 1			4	
GAS GROUP 2			120	
GAS GROUP 3			80	
GAS GROUP 4			50	
GAS GROUP 5			40	
Helium		He	4	1
Hydrogen		H2	2.02	1
Ammonia		NH3	17.03	2
Butane		C4H10	58.12	2
Krypton		Kr	83.8	2
Methane		CH4	16.04	2
Neon		Ne	20.18	2
Sulfur dioxide		SO2	64.07	2
Sulfur hexa fluoride		SF6	146.06	2
Trichloromethane		CHCl3	119.38	2
1,1,2-Trichlorotrifluoroethane	R113	C2Cl3F3	187.37	2
1,2-Dichlorotetrafluoroethane	R114	C2Cl2F4	170.92	2
Dichlorodifluoromethane	R12	CCl2F2	120.91	2
Bromotrifluoromethane	R1301	CBrF3	148.9	2
Chlorodifluoromethane	R22	CHF2Cl	86.47	2
Refrigerant R502	R502	CHClF2, CCIF2HCF3	111.6	2
Xenon		Xe	131.29	2
Acetone		C3H6O	46.07	3
Argon		Ar	39.95	3
Refrigerant R 404a	R404a	R125:143a:134a = 44:52:4	97.6	3
Refrigerant R 407c	R407c	R134a: R125: R32 = 40:40:20	86.2	3
Refrigerant R 410a	R410a	R125:R32 = 50:50	72.6	3
Refrigerant R 507	R507	CF3CH3:CF3CHF2 = 50:50	104	3
Refrigerant R 245FA	R245FA	CF3CH2CHF2	134	3
Boron trifluoride		BF3	67.81	3
Carbon dioxide		CO2	44.01	3
Deuterium oxide		D2O	20.04	3
Diethyl ether		C4H10O	74.12	3
Ethanol		C2H5OH	46.07	3
Hexane		C6H14	86.17	3
Hydrogen chloride		HCL	36.46	3
Hydrogen sulphide		H2S	34.08	3
Methanol		CH4O	32.04	3
Nitrous oxide		N2O	44.01	3
Pentane		C5H12	72.15	3
Perfluorocyclobutane	C318	C4F8	200.03	3
Tetra fluoromethane	R14	CF4	88	3
Trichlorofluoromethane	R11	CFCl3	137.37	3
Water		H2O	18.02	3
Acetylene		C2H2	26.04	4
Ethane		C2H6	32.08	4
Ethylene oxide		C2H4O	54	4
Ethylene		C2H4	28.05	4
Isobutane	R600a	C4H10	58.12	4
Propane		C3H8	44.09	4
Tetrafluoroethane	R134a	C2H2F4	102.03	4
Carbon monoxide		CO	28.01	5
Nitric oxide		NO	30.01	5
Nitrogen		N2	28.01	5
Oxygen		O2	32	5

For indication only. If in doubt, please contact Edwards quoting chemical name, and CAS number

Publication Number: 3601 0363 01 © Edwards Limited 2023. All rights reserved
Edwards and the Edwards logo are trademarks of Edwards Limited.

Whilst we make every effort to ensure that we accurately describe our products and services, we give no guarantee as to the accuracy or completeness of any information provided in this datasheet.

Edwards Ltd, registered in England and Wales No. 6124750,
registered office: Innovation Drive, Burgess Hill, West Sussex, RH15 9TW, UK.

